

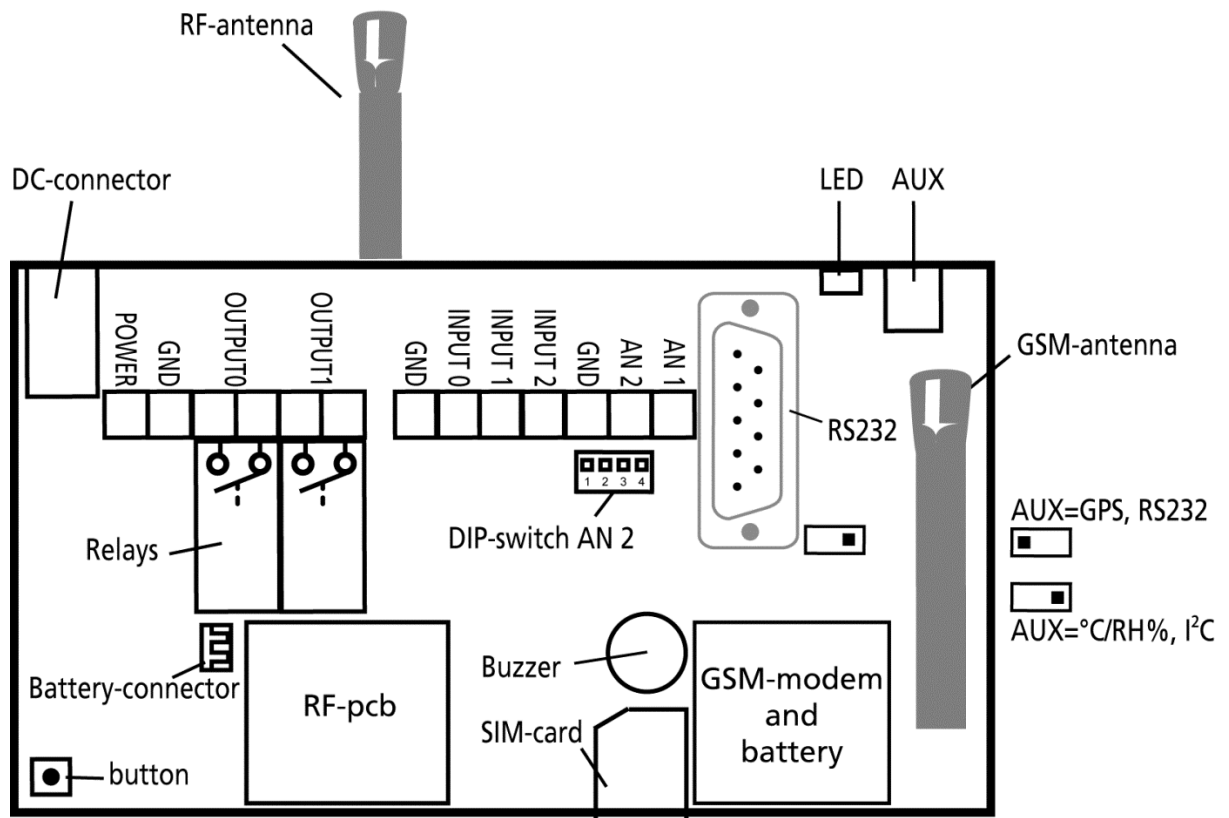

## Mounting

1. Prepare a SIM card so that the PIN code is 1234 or deactivated. Mount the card in the unit. The unit now has 1234 as password or runs without a password. The card is turned the way shown below.
2. Connect inputs, outputs and power cable (12-24 VAC/DC).
3. Connect power. The unit first gives one short beep and then a red diode is lit. After approximately 20 sec. the diode flashes every 2 sec. and the unit is ready.
4. Connect a rechargeable 3,6 V Li-ion battery.

### The unit inside



#### DIP-switch for analogue input 2 (AN 2)

1 ON:	0-10 VDC
2 ON:	0/4-20 mA
3 ON:	PT-100
4 ON:	Profort, PTC- probe
All OFF:	digital input

#### Voltage on in- and outputs

Output:	AC max 230 VAC, 6A
	DC max 30 VDC, 6A
Inputs, digital:	max 12 VDC
	max power 2 mA
Input, analogue 2:	max 0-10 VDC
	Press only voltage when DIP-switch 1 is on and 2-4 are off
Input, analogue 1:	Profort, PTC probe

## SET-UP – MANAGEMENT

### Set-up on PC via the PC COM-port



1. Connect the unit to the PC COM-port with an RS-232 cable or a USB-RS232 converter (the driver of the converter needs to be installed).
  2. Install the Profort PC Program in a computer with Windows by downloading the program from [www.profort.com](http://www.profort.com). Start the program and type in the product key which can be found on the page.
  3. Type in the number of the COM-port that the PC uses.
  4. Fill in the rest of the information in the set-up program and finish with transferring it to the unit.
- 

### Set-up via masterView



1. Open a browser on your PC, tablet or smartphone.
  2. Type <http://setup.masterview.dk> in the address bar, and choose 'setup' (or login via [www.profort.dk](http://www.profort.dk)). Log on to the portal or create yourself as user. An unlimited number of units can be connected to any user, and several users can be connected to the same units.
  3. Create a new unit in the list and choose multiGuard Technic IO as unit. When you press SAVE the portal sends a text message to the unit, which connects it to the Profort server via GPRS/Internet on the SIM-card. The USERNAME of the unit will now be its telephone number (to be used, if controlling the unit via the Profort app). All communication will then take place as data.
  4. Type in the required information and press 'send and save'.
  5. The unit is now ready to use.
-



## Set-up with text message



1234 = password, 0 = zero, space counts as a character and is therefore important.

Define the phone number of the unit and (optionally) change password	1234 N0 xxxxxxxx yyyy (N0 = N + zero)	xxxxxxx = the unit phone no. yyyy = new four digit password Defines unit phone no. (N0) and create new password. New password is not necessary.
<b>Receivers</b>		
Register no. 1, no. 2 and so on	1234 N1 11111111 1234 N2 22222222	Registers receiver 1 and 2 to receive text to phone number 11 11 11 11 and 22 22 22 22 All in all 25 receivers.
Delete no. 1	1234 N1	Deletes receiver 1
<b>Text on inputs</b>		
Create	1234 Ax TEXT	TEXT on input x by opening/closing. x = 0,1, or 2
	1234 Lx TEXT	TEXT on input x by opening/closing. x = 0,1 or 2
Delete	1234 Ax	Deletes TEXT for input x by opening/closing. x = 0, 1 or 2.
	1234 Lx	Deletes TEXT for input x by opening/closing. x = 0, 1 or 2
Only alarm if text is created	1234 CT	The unit ignores input that does not have text connected to it
Create analogue input	1234 V1 S yyyy zzzz 1234 V1 M yyyy zzzz	Set-up of the scale (yyyy = minimum zzzz = maximum) for 0-10 V and for 0-20 mA. Set-up of values for intervals LOW, MIDDLE and HIGH (Point 1 and Point 2) on analogue input 1. If the value on input becomes larger or smaller than yyyy (Point 1) or larger or smaller than zzzz (Point 2), an alarm is sent.
	1234 V1 A TEXT	Alarm text LOW on analogue input 1 is sent when the value becomes smaller than the value defined in Point 1/yyyy (Vx M yyyy zzzz).

## SET-UP – MANAGEMENT

	1234 V1 L TEXT	Alarm text MIDDLE on analogue input 1 is sent when the value becomes higher than the value defined in Point 1/yyyy or lower than the value in Point 2/zzzz (Vx M yyyy zzzz).
	1234 V1 B TEXT	Alarm text HIGH on analogue input 1 is sent when the value becomes higher than the value defined in Point 2/zzzz (Vx M yyyy zzzz).
Activate output in case of alarm	1234 Gx	x = 1-9 (1 = 10 sec., 2 = 20 sec., 3 = 30 sec., 4 = 1 min, 5 = 2 min, 6 = 4 min, 7 = 8 min, 8 = 16 min and 9 = constant.)  Sets the relay output to activate in x time in case of alarm on an input.
Outputs follow condition on inputs	1234 GA	Indicates that the output follows the corresponding input if text is created.  Notice: input signal has higher priority than command S0 (S + zero) and B0 (B + zero)

---

For further help: see the manual on the CD or on [www.profort.com](http://www.profort.com)

---

## Management of relay and functions with call from telephone

### Relay:

Call the unit. Type in 1234 (password) when the connection is established, and await two 'beeps'. Type in the chosen code and end the call.

Code examples:

*00 (asterisk + zero + zero)	Pulses relay output for 10 sec.
*10 (asterisk + 1 + zero)	Opens relay output
*20 (asterisk + 2 + zero)	Closes relay output

### Macro:

Call the unit. When the connection is established, type in the chosen code and end the call.

x (x = 0-9 for macro 0-9)	Executes macro x
---------------------------	------------------

---

## MANAGEMENT

### Management with text message

Connect and disconnect the unit	1234 ON	Inputs are activated, red diode flashes
	1234 OF	Inputs are deactivated, red diode turns off
Activation of output	1234 S0 (S + zero)	Closes output
	1234 B0 (B + zero)	Opens output
	1234 P0 (P + zero)	Pulses output for approx. 10 sec.
Download	1234 OK	Downloads info about GSM rf power and battery level. Example: OK>>OK SQ: xx% BAT: yyV  xx = rf power in percent.25 % is lowest acceptable value yy = battery status
	1234 V1 R	Downloads measurements on the analogue input
Connection to the Internet	1234 EH USERNAME	GPRS traffic starts
	1234 EH	GPRS traffic stops
Send alarm immediately in case of power failure	1234 JS	Sends alarm immediately in case of power failure (after approx. 10 sec.)
	1234 JM	Sets the unit to send alarm in case of power failure after approx. 30 min. (Default setting)

### Other management

The unit can also be managed through the pc program and all the functions can be controlled directly on the Internet.

At the bottom of the print there's a button with the following functions:

1. If button is pressed down while power supply is connected, a beep sounds after 7 seconds. This sets the unit to factory settings.
2. If button is pressed down during normal operation, a 'beep' sounds after 7 seconds. If button is released immediately hereafter, macro 1 is performed. If no function has been saved behind macro 1, nothing happens.
3. If button is kept down then after 14 secs., another 'beep' sounds. This activates sabotage.
4. Press the button briefly to add a wireless detector. The sounder now gives continuous quick beeps. While the sounder is active, the detector alarm is activated. Only activate one detector at a time. When the detector is accepted, the sounder gives 2 quick beeps and stops.

See more in the manual or for Internet management log on [www.profort.com](http://www.profort.com)

# MACRO

## Macro with command

Collect one or more commands in a 'super command' called a macro. Give it a name and activate it with that name. It works with either text message, phone call, DTMF-tones, or over the Internet. It is possible to create 10 macros.

A macro can be created with commands or with infrared codes from e.g. a remote control.

Create macro no. 1 with command	1234 M1 NAME <COMMAND> E.g. 1234 M0 TEMP <VI R>	Creates macro M0 .. M9 with the name NAME and attaches a command. More commands in the same macro are divided by semicolon ',' without space. Example: 1234 SHORT PULSE <S0;B0>
Play macro	TEMP	Plays the macro with the name TEMP
Delete macro no. 1	1234 M1	Deletes macro 1 (M0..M9).

---

For further help: see the manual on the CD or on [www.profort.com](http://www.profort.com)

---

## Connection of temperature probe

The unit has a built-in plug (AUX) for montage of e.g. temperature probe.

The built-in switch must be placed on the left side for the probe to be used. For the probe to measure humidity and temperature the GSM unit needs to be set up. In following example boundaries are set at 4°C and 30°C by temperature and at 35% RH and 65% RH by the relative humidity.

Analoge indgange													
Type	Skala min	Lav tekst	Zone	Punkt 1	Mellem tekst	Zone	Punkt 2	Høj tekst	Zone	Skala max	S/F i %	Filter	Send
1	<input type="checkbox"/>	<input type="text"/>	<input type="checkbox"/>	<input type="text"/>	<input type="text"/>	<input type="checkbox"/>	<input type="text"/>	<input type="text"/>	<input type="checkbox"/>	<input type="text"/>	<input type="checkbox"/>	<input type="checkbox"/>	<input type="checkbox"/>
2	<input type="checkbox"/>	<input type="text"/>	<input type="checkbox"/>	<input type="text"/>	<input type="text"/>	<input type="checkbox"/>	<input type="text"/>	<input type="text"/>	<input type="checkbox"/>	<input type="text"/>	<input type="checkbox"/>	<input type="checkbox"/>	<input type="checkbox"/>
3	<input type="checkbox"/>	Profort Temp.	<input type="checkbox"/>	4	TEMP OK	<input type="checkbox"/>	30	TEMP HØJ	<input type="checkbox"/>		<input type="checkbox"/>	<input type="checkbox"/>	<input checked="" type="checkbox"/>
0	<input type="checkbox"/>	Profort Fugt	<input type="checkbox"/>	35	FUGT OK	<input type="checkbox"/>	65	FUGT HØJ	<input type="checkbox"/>		<input type="checkbox"/>	<input type="checkbox"/>	<input checked="" type="checkbox"/>

---

For further help: see the manual on the CD or on [www.profort.com](http://www.profort.com)

---

# SPECIFICATIONS

## Power supply

12-24V DC min 0,5 A (included)

## Battery

3,6V rechargeable Li-ion battery (included)

## Consumption

Approx. 35 mA while resting (supplied with 12VDC)

150 mA when charging with battery

2 mA in case of power failure and supply with battery

## Output

Max 6 A at 230V AC

Max 6 A at 35V DC

## Inputs, digital

Max 1V, 2 mA (GND)

Min. 18V max 30 V (24V DC)

Input 0: also dis-/connection (level/pulse)

Input 1: also pulse/minute counter

Input 2: also pulse counter

## Input, analogue 1 (AN 1)

Profort temperature sensor (Profort-no. 007995)

## Input, analogue 2 (AN 2)

0-10V DC

0/4-20mA

PT-100

Profort temperature sensor (Profort-no. 007995)

## Pulse and minute counter

Max 10Hz. Max one mio. pulse or minutes

## Dimension

Design box, black

130x85x24 mm, weight: 125 g.

## Temperature

- 20 °C - +55 °C

## Antenna

1 internal antenna for GSM-modem. Possibility for external antenna (Profort-no. 369003)

1 internal antenna for RF. Possibility for external antenna (Profort-no. 369003)

## The Profort PC Program

Compatible with all versions of Windows. The PC needs to have a COM-port (RS232). A USB-RS232-converter or connection through Internet via GRPS must be used.

Download the program from [www.profort.com](http://www.profort.com). NB! Product key for the PC program is also found on [www.profort.com](http://www.profort.com).

## OTHER PRODUCTS IN THE SERIES

### GSM unit – 9 modules

- 4 relay outputs
- 8 digital inputs
- 2 analogue inputs
- 230V/12-24V 3,6V Li-ion back-up battery (inclusive)
- 9V rechargeable back-up battery (acquisition)
- DIN wall mount modules



### multiGuard® Master RF

- 8 relay outputs
- 8 digital inputs
- 4 analog inputs
- Wireless 868 Mhz receiver
- 230 V / 12-24 V power supply
- 9 V rechargeable back-up battery (acquisition)
- Modbus interface
- IP-65 box
- Touch display for set-up and programming



### multiGuard® Remote IO

- 1 relay output
- 2 senders of infrared codes for heat pump control
- 3 digital inputs
- 1 built-in temperature and humidity sensor
- 1 recorder for infrared codes
- 12 VDC power supply (inclusive)
- 3,6 V Li-ion back-up battery (inclusive)
- Design box for wall mount
- Plug for external IR-transmitter



### IP-65 box for multiGuard® DIN4/6/9-series

- Waterproof box
- DIN-rail for 4/6/9 modules
- 3 PG inputs

